



TetraGraph Connectivity Solutions

# Philips IntelliVue

TetraGraph® sets the standard for seamless integration in quantitative train-of-four (TOF) monitoring, offering unmatched connectivity across leading patient monitoring platforms. Designed to fit effortlessly into existing anesthesia workflows, its advanced interface ensures real-time, reliable data transmission, enhancing clinical decision-making and patient safety.

# CONNECT VIEW TRANSFER

As the market leader in interoperability, TetraGraph provides hospitals and anesthesia providers with a future-ready solution that optimizes efficiency and standardizes neuromuscular monitoring across diverse healthcare environments. With a strong focus on flexibility and ease of integration, it connects with a wide range of monitoring systems, eliminating barriers to adoption and streamlining implementation. By connecting through TetraHub™, Senzime empowers clinicians with the tools they need to enhance perioperative care.



## Required parts from Senzime

**SEN2015**  
TetraGraph

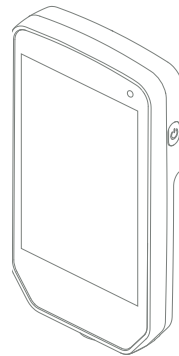

**SEN2017**  
TetraHub

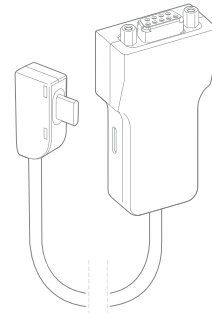

**SEN2017\***  
includes a  
DB9 extension  
cable

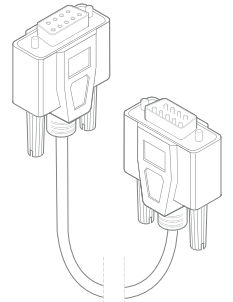

\*This is not needed for Philips Monitor Connection.



## Required parts from Philips

- IntelliBridge EC5 Open Interface Adapter – **NEW**
- IntelliBridge EC10 Module with Open interface Driver version A.6 or higher
- Connection cable



Philips EC5  
RS232 cable Adaptor



Philips  
Connection Cable



Philips EC10  
Device Interfacing Module



Philips  
IntelliVue Patient Monitor

## Getting to Know TetraHub

### Device Layout

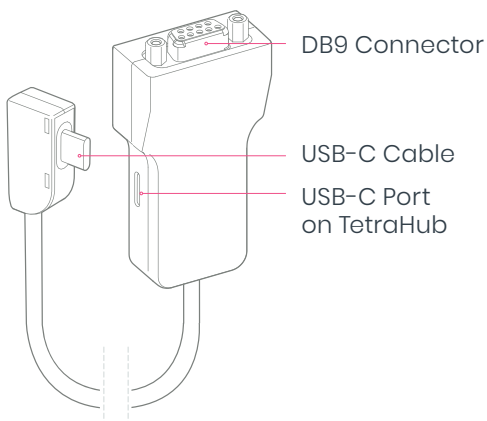

## Setting Up

### Connecting TetraHub to TetraGraph and external monitor/hub

1. Disconnect the power supply cable (1) from the USB-C port (2) on the back of the TetraGraph monitor.
2. Connect the TetraHub's integrated USB-C cable (3) to the USB-C port (2) on the back of the TetraGraph monitor.
3. Connect the TetraGraph power supply cable (1) to the USB-C port on TetraHub (4).
4. Connect the DB9 connector of TetraHub (5) to the Philips EC5.

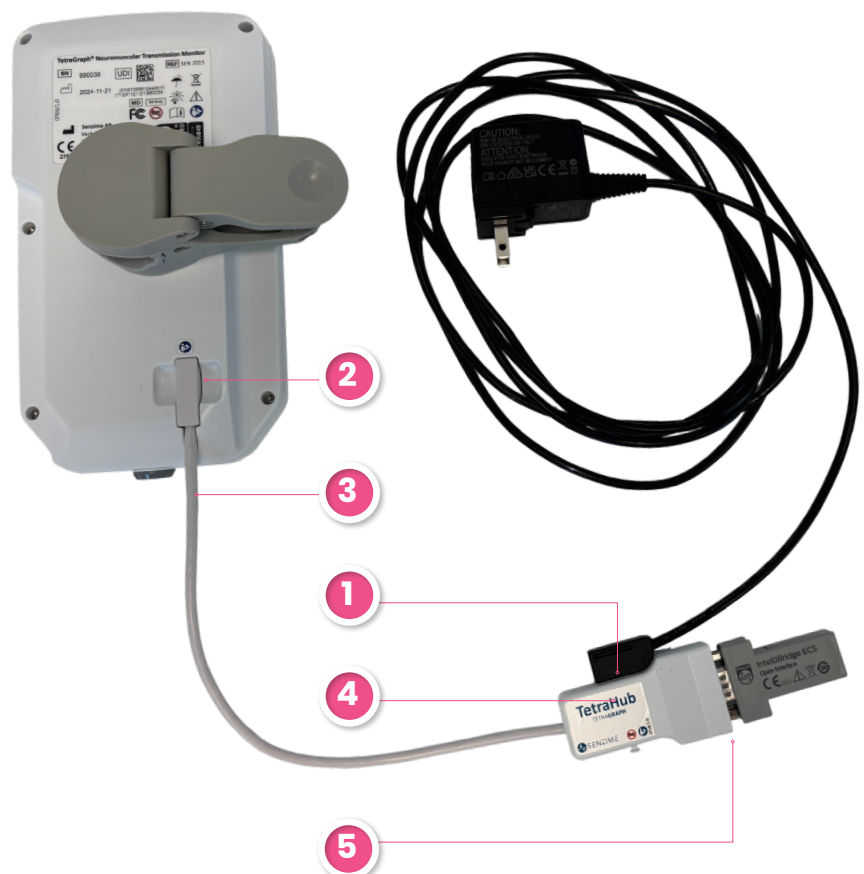

## Philips Data Cable Part Numbers and Required Components

Product Name	Part Number	Option Number	Connector
IntelliBridge EC10	865115	101	Open interface driver
IntelliBridge EC5	865114	101	DB9 Male
Connection Cable (different length)	PN 865114 opt L01 Connection Cable 1.5m PN 865114 opt L02 Connection Cable 3.0m PN 865114 opt L03 Connection Cable 10m		

When the TetraGraph monitor is connected to the Philips IntelliVue monitor using TetraHub, the following data is transmitted to the external device:

- TetraGraph monitor identification (Serial number and software version)
- Pulse information
- Measurement and status flags
- TOF, PTC, and ST results
- Individual peak-to-peak amplitudes
- EMG waveforms

## Operation

Consult the user manuals for the TetraGraph monitor and any connected external devices for device-specific handling and instructions for use.



### Starting measurement sessions

1. Turn ON the TetraGraph monitor.
2. Settings > Device > Communication > IntelliVue.
3. Check that the external monitor indication symbol is displayed in the information bar on TetraGraph.



External Monitor Indicator

4. Connect the patient to the system.
5. Start TOF measurements.
6. The external hub or monitor will start displaying information from the TetraGraph monitor.

### Finishing measurement sessions

Consult the user manual for the corresponding external hub or monitor to shut down the device. Consult the IFU for the TetraGraph monitor to shut down the device.

Disconnect TetraHub from the power supply, the external hub or monitor, and the TetraGraph monitor. Proceed to clean and disinfect TetraHub.



## Data Mapping

- A request is submitted by a stakeholder (e.g., MD, IT representative, Biomed, Anesthesia Manager) to the EMR/IT team.
- Three data fields should be added to the Anesthesia Chart: TOFr, TOFc, and PTC.

**Key data points to consider for EMR integration. For a complete list, see the table below.**

Parameter Label	Description	MDIL Text ID	Range	Unit
TOFrat	Train-of-four (TOF) ratio: the ratio between the first and the fourth TOF response	0002-f897	0-100	Percent
TOFcnt	Train-of-four (TOF) count: the number of TOF responses	0002-f8ab	0-4	Unitless
PTC	Post tetanic count (PTC): the number of responses following tetanic stimulation, used to assess deep levels of neuromuscular block	0002-f88b	0-20	Unitless

## List of Labels

**In the table below, all labels are provided with numeric codes from the Medical Device Interface Language (MDIL).**

MDIL Text ID	Label	Unit of Measure	Display Range	Definition	Description
002-593c	EMG	Percent	0-120	"EMG"	Electromyography Low EMG
002-f8ab	TOFcnt	Unitless	0-4	"TOFcnt"	Train-of-four (TOF) count – Number of TOF responses
002-f897	TOFrat	Percent	0-120	"TOFrat"	Train-of-four (TOF) ratio – the ratio between the first and fourth TOF response
002-f88b	PTC	Unitless	0-20	"PTC"	Post Tetanic Count stimulation – PTC
002-f8ac	Twitch	mV	0-50	"Twitch"	Twitch height of the 1Hz/0.1Hz stimulation response
002-f8a7	TOF1	mV	0-50	"TOF1"	Train-of-four (TOF) first response value
002-f8aa	TOF4	mV	0-50	"TOF4"	Train-of-four (TOF) fourth response value
002-f8a8	TOF2	mV	0-50	"TOF2"	Train-of-four (TOF) second response value
002-f8a9	TOF3	mV	0-50	"TOF3"	Train-of-four (TOF) third response value

### Disclaimer:

All product names, logos, and brands are the property of their respective owners. Any reference to third-party products is for informational purposes only and does not imply endorsement or affiliation with Senzime.



For the full TetraHub Instructions for Use (IFU), visit:  
[senzime.com/instructions-use](https://senzime.com/instructions-use)